

The INT90 Tenderiser is a hard-working, heavy duty* machine designed to produce “fillet” results from less valued cuts of meat.

- **Gear Drive**
Powerful, heavy duty operation with fan-cooled* motor for continuous service
- **Available in 3-phase form**
- **Comprehensive electrical and mechanical safety features**
- **Stir-fry attachment**
make perfect stir-fry strips every time.
- **Easy cleaning**
Machine disassembles quickly for effective cleaning.
- **CE approved.**



Model
INT90
Tenderiser



Medium/Heavy Duty; Gear-driven; Manual operation

* INT90 Fan Cooled and INT112 only

Model INT90 Tenderiser

CE Approved

The INT90 Tenderiser has been designed to produce "fillet" results from less valued meats. Hundreds of small blades penetrate the meat, cutting the muscle fibres, making it tender and succulent during the cooking process.

The INT90 is available in two configurations: Standard and Fan-cooled. The Fan-cooled option provides forced ventilation and cooling to the motor for heavy duty applications. The INT90 is available in either single or 3-phase versions.

The unique Stir Fry cutting group slices meat into strips perfect for oriental cuisine.

- The INT90 is manufactured in anodised aluminum to resist the corrosive effects of salts and acids.
- Blades stop when protective cover is raised.
- High mouth position and lower blade enclosure ensure operator safety.
- Reduces meat cooking times.
- Reversing switch.
- CE Approved.

Tenderiser blade group

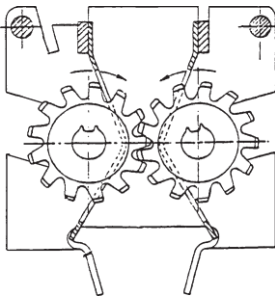

Strip cutter blade group

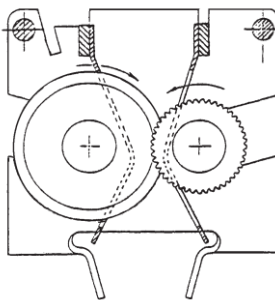

SPECIFICATIONS

Standard cutting group blades	2 x 44
Product Feeding Speed	20cm/sec
Stir Fry cutting group	4mm/44 6mm/30 8mm/22 12mm/15
Motor	400W, Single phase, 240V 50Hz or 500W, 3-phase, 415V, 50Hz
IP Rating	55
Net weight	- INT90 22kg - INT90FC 22.5kg

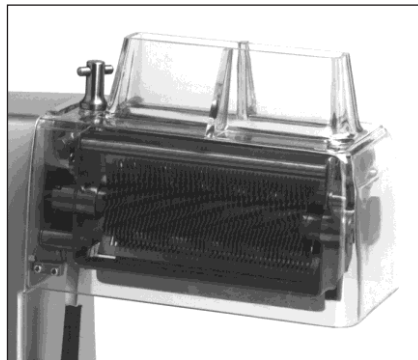
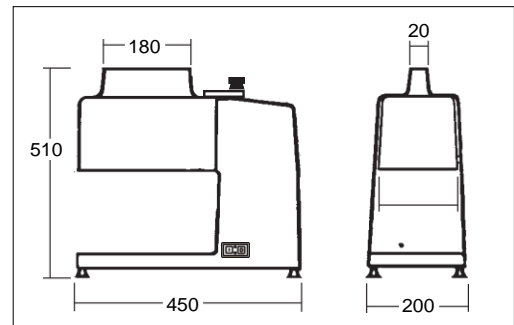

The clear protective cover of the INT90 allows the operator to keep an eye on the meats being processed.

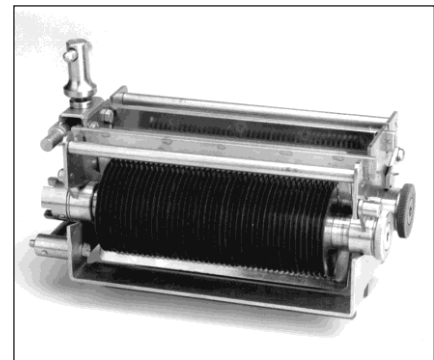

The Stir Fry cutting group is perfect for oriental cuisine.



Servicing NSW and ACT

Ph: 02 4879 3808

www.briquip.com.au

admin@briquip.com.au