

mGate®

Secure exit at the checkout and information area



mGate®

Comfort checkout barrier and electronic swing doors

- > Controlled by Checkout Manager PRO, control panel, RFID, LAN, etc.
- > Panic alarm and double-sided panic function as standard
- > Automatic swivel barrier/swivel arm reset



Pat. pend.

Electromagnetic
Compatibility (EMC)
certification



Design pend.

MGATE®
Basic design with flange, Classic swivel barrier and white sign with "no entry" symbol



Design pend.

MGATE® COLOUR
Basic design with flange and ESG safety glass Colour swivel arm with illuminated "no entry" symbol (design example available on request)

Title page illustration

MGATE® COLOUR

Basic design with base, Colour Classic swivel barrier and sign with illuminated "no entry" symbol

mGate®/mGate® Colour

■ The **mGate® barriers** are the most modern and innovative of their kind. The intelligent control electronics enable reliable operation at all times and allow you to specially adapt the product to your needs. The improved design, new functions and diverse barrier options expand the application range for check-out and information areas, etc.

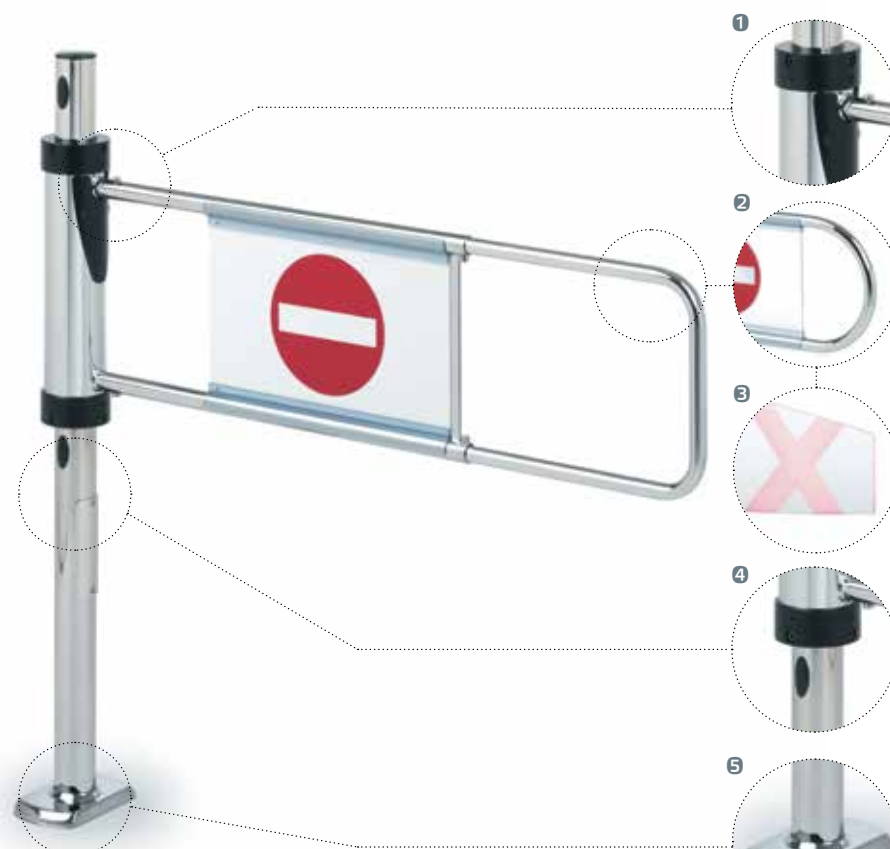

MGATE®

Basic design with base, extending swivel barrier and white sign with "no entry" symbol

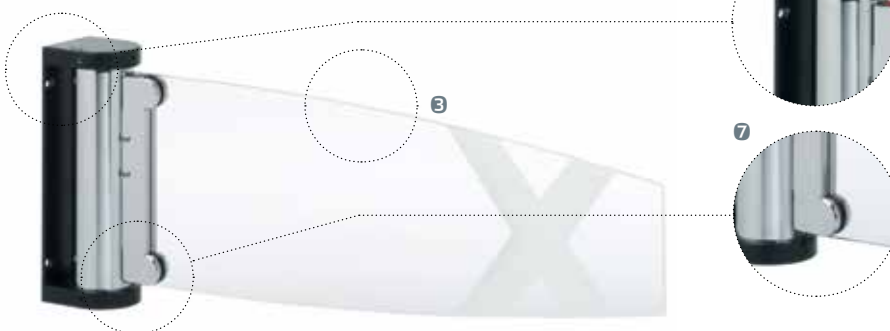

MGATE®

Basic design with flange and ESG safety glass swivel arm with "no entry" symbol (design example available on request)

1 SWIVEL COMPONENT

With connecting ports for installing the Classic or Colour Classic swivel barriers

2 SWIVEL BARRIER

With white or transparent sign

- made from sturdy steel tube in three lengths
- made from sturdy steel tube, extendable
- made from sturdy steel tube in high model, extendable

With illuminated sign

- made from sturdy steel tube in three lengths
- made from sturdy steel tube, length-adjustable

SIGN (EXAMPLE)

Illuminated acrylic glass design with "no entry" symbol

3 SWIVEL ARM

Made from shatter-proof ESG safety glass

- for individual lettering
- with "no entry" or "arrow" symbol

Colour made from shatter-proof ESG safety glass

- for individual lettering
- with "no entry" or "arrow" symbol
- visual light guide with LED light strip
- customisable colour options

SWIVEL ARM (EXAMPLE)

ESG safety glass design with "no entry" symbol

4 BASE

Sturdy steel tube Ø 60 mm

Connections for Classic customer guidance system available as standard in 90°, 180° and 270° versions and covered with plastic caps

5 BASE PLATE

Four screw connections

Slots for precise alignment

Base plate cover made from steel plate

6 FLANGE

Sturdy assembly plate with four fixing holes

7 SWIVEL COMPONENT

With holders for ESG safety glass swivel arms or ESG safety glass Colour swivel arms

Please note: mGate and mGate Colour are not entrance systems, exit systems or exit gates. They are only to be used for the information area or as check-out barriers.

mGate®/mGate® Colour

Reducing inventory differences

When checkouts are not in use, the mGate® ensures that customers can only pass through staffed checkouts. Your staff are immediately alerted of any attempts at manipulation by means of an alarm.



Opening up escape routes

In the event of an emergency, the system opens up the checkout area/exit to provide an escape route. To restore normal operational readiness, the mGate® returns to its original position completely automatically.



Design

Basic design with base: Base with base plate and base plate cover for floor mounting. Casing for swivel mechanism with high-gloss chrome or coloured plastic powder coating. Energy-saving brake system. Fitted with panic alarm and double-sided panic function as standard and connections for attaching the Wanzl Classic customer guidance system.

Basic design with flange: Sturdy assembly plate for installation on cash desks or walls. Casing for swivel mechanism with high-gloss chrome or coloured plastic powder coating. Energy-saving brake system. Fitted with panic alarm and double-sided panic function as standard.

Swivel barriers: Sturdy steel tube with white or transpar-

ent plastic sign, available with either "no entry" symbols on both sides or with an "arrow" symbol on the front and a "no entry" symbol on the back.

Colour swivel barrier: Sturdy steel tube with illuminated glass sign with "no entry" symbol visible on both sides.

ESG swivel arm: Shatter-proof ESG safety glass for individual lettering or with "no entry" symbol.

ESG Colour swivel arm: Shatter-proof ESG safety glass for optimal light guidance, for individual lettering or with "no entry" symbol and LED light strip at bottom. LED light colour can be customised.

Basic design with base

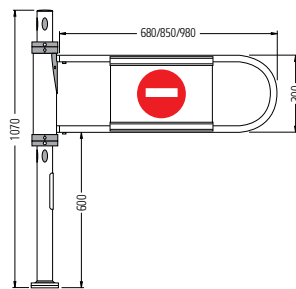
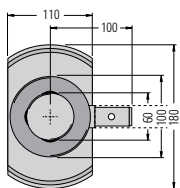

with Classic swivel barrier

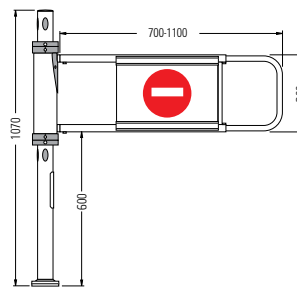

with extending swivel barrier

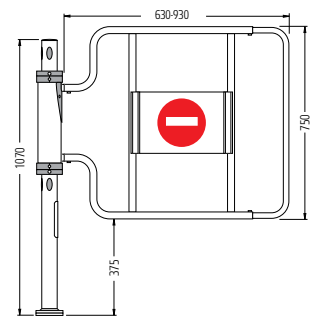

with high model swivel barrier

Basic design with flange

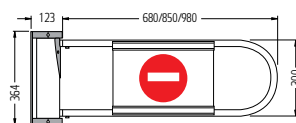
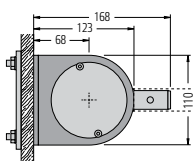

with Classic swivel barrier

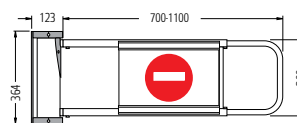

with extending swivel barrier

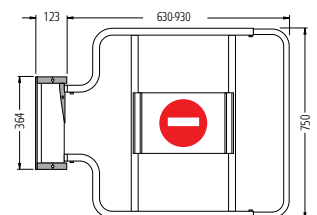

with high model swivel barrier

Practical exits, attractive passageways

Functions

Adjustable opening angle (0-180°), can be programmed.
Reliable and precise locking mechanism. Automatic barrier reset and double-sided anti-panic feature.

Control

Controlled by checkout computer, Checkout Manager Pro, RFID, network module WENI control with LAN connection, control panel or button. In combination with Checkout Manager Pro, the mGate® opens and closes automatically when the operator logs in or out of the checkout.

Electronic anti-panic feature

Double-sided with acoustic panic alarm and automatic swivel barrier/swivel arm reset.

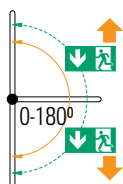

Exit
Exit

Minimum energy consumption

Operating voltage of 24 V for optimum safety; systems therefore comply with national and international safety requirements. Energy-saving thanks to fail-safe brake – the brake fixes the swivel barrier/arm in the latching positions without consuming electricity.

Accessories

RFID sensor for opening using card or key ring (e.g. time recording). After release, the **Push2Go function** is activated and the barrier is opened by gently pushing it in the required direction of passage.

Control panel, control panel with WENI control or **button** for manual opening.

Webserver (software) for control panel with WENI control, can be operated using a web browser on a tablet or smartphone.

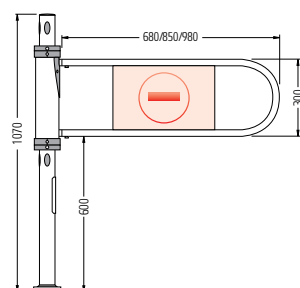

with Colour Classic swivel barrier

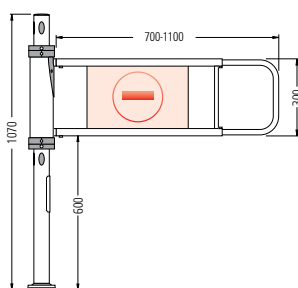

with length-adjustable Colour swivel barrier

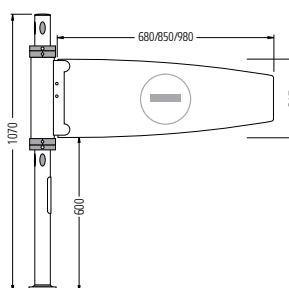

with ESG safety glass swivel arm with "no entry" symbol

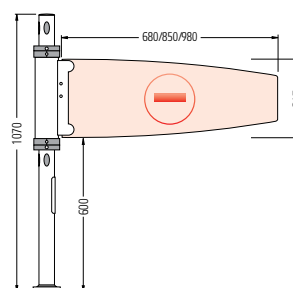

with ESG safety glass Colour swivel arm with "no entry" symbol

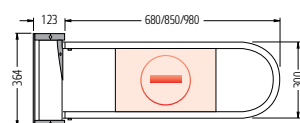

with Colour Classic swivel barrier

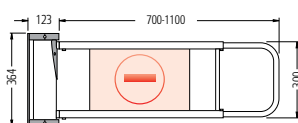

with length-adjustable Colour swivel barrier

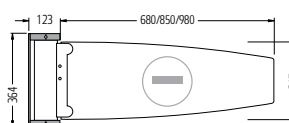

with ESG safety glass swivel arm with "no entry" symbol

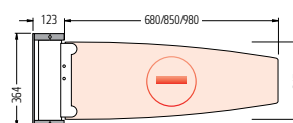

with ESG safety glass Colour swivel arm with "no entry" symbol

mGate® Checkout/mGate® Checkout Colour

mGate® Checkout		With base		With flange	
Basic design		For swivel barrier		For swivel barrier	
Basic design without swivel barrier, 1 m connecting cable Designs with high-gloss chrome or plastic powder coating		Order no.		Order no.	
		23.51795.10/73-9005*		23.51790.10/73-9005*	
Colour basic design		For Colour swivel barrier		For Colour swivel barrier	
Colour basic design without swivel barrier, 1 m connecting cable Designs with high-gloss chrome or plastic powder coating		Order no.		Order no.	
		23.51796.10/73-9005*		23.51791.10/73-9005*	
Basic design		For ESG safety glass swivel arm		For ESG safety glass swivel arm	
Basic design without swivel arm, 1 m connecting cable Designs with high-gloss chrome or plastic powder coating		Order no.		Order no.	
		23.51797.10/73-9005*		23.51792.10/73-9005*	
Colour basic design		For ESG safety glass Colour swivel arm		For ESG safety glass Colour swivel arm	
Colour basic design without swivel arm, 1 m connecting cable Designs with high-gloss chrome or plastic powder coating		Order no.		Order no.	
		23.51798.10/73-9005*		23.51793.10/73-9005*	

Accessories: RFID sensor and Push2Go function			
Order no.	RFID module for base design	RFID module for flange design	Key
	23.79136.95-0000	23.73128.95-0000	98.76110.00-0000
Releases barrier with card or key ring and opens it in the required direction of passage with a gentle touch			

* Example orders: 23.51795.10-9005 high-gloss chrome,
23.51795.73-9005 plastic powder coating,
colours available upon request.

Perfect system

Swivel barriers/swivel arms					
Classic swivel barrier					
	Bar length	Sign with		Sign with	
		White	Transparent	White	Transparent
	680 mm	23.38307.10-0005**	23.38307.10-0000**	23.38307.10-0004**	23.38307.10-0003**
	850 mm	23.72235.10-0000**	23.38194.10-0000**	23.38194.10-0004**	23.38194.10-0002**
	980 mm	23.53583.10-0000**	23.38420.10-0000**	23.38420.10-0004**	23.38420.10-0002**
Extending swivel barrier					
	Bar length	Sign with		Sign with	
	Height 300 mm, extendable 700 - 1,100 mm	White	Transparent	White	Transparent
		00.90271.10-0003**	00.90271.10-0002**	00.90271.10-0000**	00.90271.10-0001**
High model swivel barrier					
	Bar length	Sign with		Sign with	
	Height 750 mm, extendable 630 - 930 mm	White	Transparent	White	Transparent
		23.29498.10-0004**	23.29498.10-0002**	23.29498.10-0000**	23.29498.10-0005**
Colour Classic swivel barrier, sign with "no entry" symbol					
	Bar length	Order no.			
	680 mm	23.67949.10-0000**			
	850 mm	23.65124.10-0000**			
	980 mm	23.68740.10-0000**			
Colour length-adjustable swivel barrier, sign with "no entry" symbol					
	Bar length	Order no.			
	300 mm high, length-adjustable 1,100 - 750 mm	23.65011.10-0000**			
ESG safety glass swivel arm for individual lettering					
	Arm length	In both directions			
	680 mm	23.62760.00-0000			
	850 mm	23.62772.00-0000			
	980 mm	23.62785.00-0000			
ESG safety glass swivel arm with "no entry" symbol					
	Arm length	In both directions			
	680 mm	23.64001.00-0002			
	850 mm	23.64014.00-0002			
	980 mm	23.64028.00-0002			
ESG safety glass Colour swivel arm for individual lettering					
	Arm length	In both directions			
	680 mm	23.62870.00-0000			
	850 mm	23.62882.00-0000			
	980 mm	23.62896.00-0000			
ESG safety glass Colour swivel arm with "no entry" symbol					
	Arm length	In both directions			
	680 mm	23.64112.00-0002			
	850 mm	23.64135.00-0002			
	980 mm	23.64151.00-0002			

Accessories: control panels/button					
Control panel		Control panel with WENI control		Button	
Order no.	98.76201.00-0000	Order no.	98.76204.00-0000	Order no.	23.79249.95-0000
For manual opening		With network card***		For manual opening	
Order connecting cable separately, max. 50 m available		For manual opening		Feed line 5 m	
		Order connecting cable separately, max. 50 m available		Connecting cable max. 50 m available	

** Swivel barrier with high-gloss chrome finish.
Swivel barriers with stainless steel or plastic powder coating available on request.

*** Accessories for control panel with WENI control: Webserver 98.76287.00-0000

Connecting cables for control panels: 5 m 98.76206.00-0000
15 m 98.76207.00-0000
30 m 98.76335.00-0000
Patch cables: 5 m 98.74362.00-0000
15 m 98.74364.00-0000

wanzl



GERMANY

Wanzl Metallwarenfabrik GmbH
Rudolf-Wanzl-Straße 4
89340 Leipheim

Phone +49 (0) 82 21 / 7 29-0
Fax +49 (0) 82 21 / 7 29-1000

info@wanzl.de
www.wanzl.com

GREAT BRITAIN

Wanzl Ltd.
Europa House
Heathcote Lane
Warwick CV34 6SP

Phone +44 (0) 1926/45 1951
Fax +44 (0) 1926/45 1952

enquiries@wanzl.co.uk
www.wanzl.co.uk

AUSTRALIA

Wanzl Australia Pty. Ltd.
97 Highbury Road
BURWOOD VIC 3125

Phone +61 (0) 3 / 98 08 22 99
Fax +61 (0) 3 / 98 08 22 66

info@wanzl.com.au
www.wanzl.com.au

KES · 10/2016 · Dimensions in mm. Specifications approximate. Colours similar to RAL. Design subject to changes. Illustrations may show optional equipment.
© Copyright by Wanzl 2014

Brochure no. 1 189/2014 · EN