

The CE653 fully automatic patty maker can produce 2,100 patties per hour.

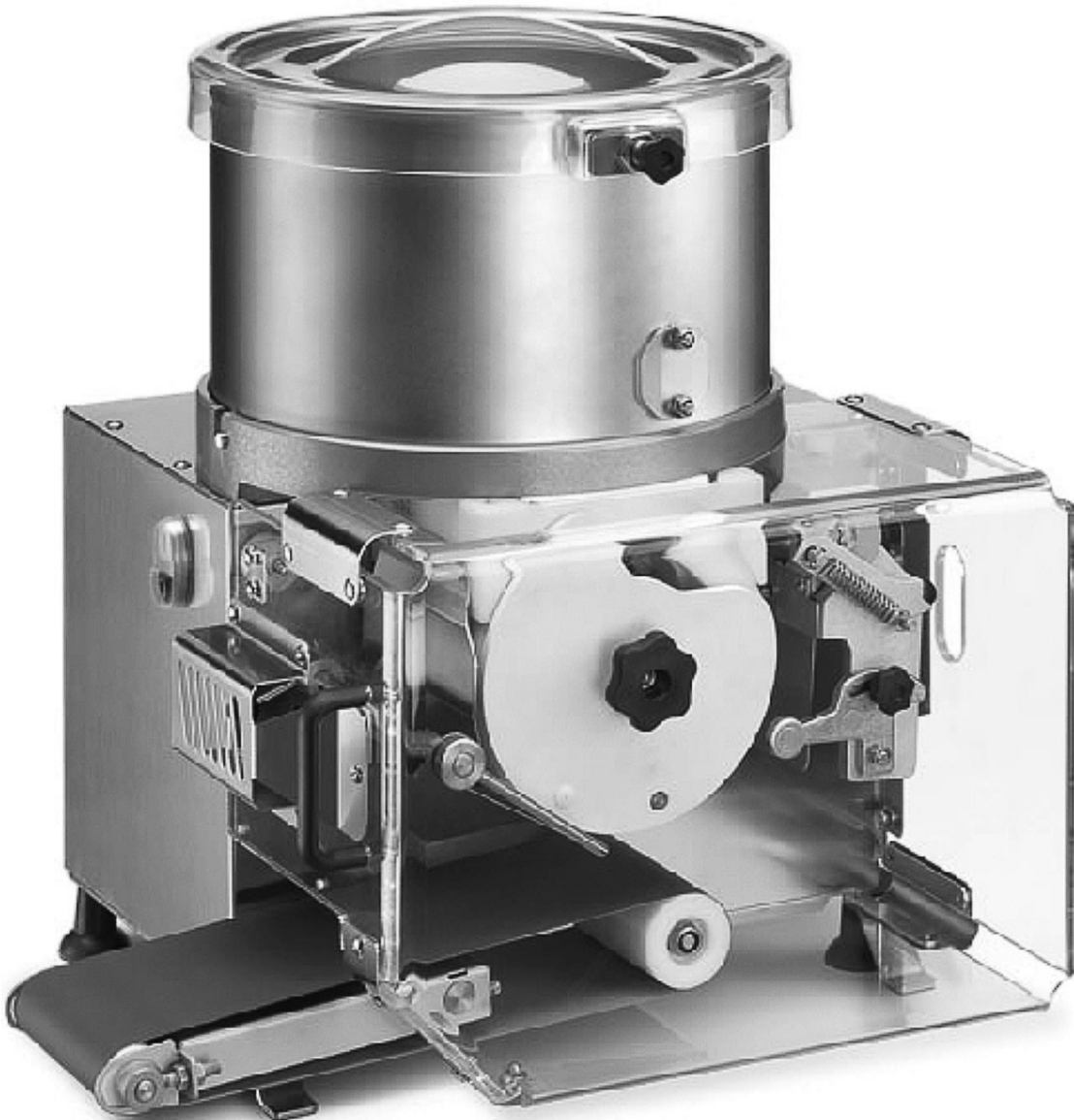

Model

LAMCE653

Fully Automatic Patty Maker



Heavy Duty Continuous; Fully automatic; CE Approved

Model LAMCE653

Fully Automatic Patty Maker

The CE653 fully automatic patty maker is constructed of stainless steel and anodised aluminum. Capable of producing 2,100 patties per hour.

- 23 Litre feeder/hopper.
- Interchangeable forming rollers with food-safe polyethylene ejector.
- Conveyor belt.
- Thickness maybe easily adjusted to obtain desired weight of patty.
- Easy to dismantle for cleaning.
- Fitted with safety interlock switch for greater operator safety.
- Also available:
Special forming cylinders, automatic wrapping device, variable speed, large 40 litre feeder/hopper, vfoot control. Refrigerated model also available (CE653R). Also available in 3 phase 415V.
- CE Approved.

SPECIFICATIONS

Dimensions (mm)

Width	555
Depth	625
Height	650
Power	1HP, 650w
Production (p/hr)	2,100 patties
Capacity (ltr)	23
Net weight (kg)	59

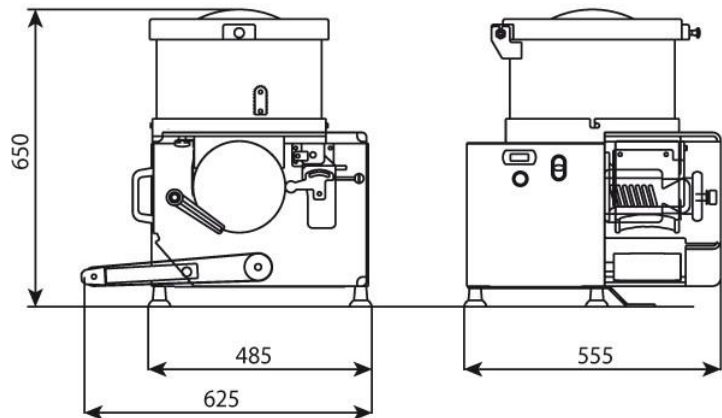

Servicing NSW and ACT

Ph: 02 4879 3808

www.briquip.com.au

admin@briquip.com.au