

# MKF 511 TS

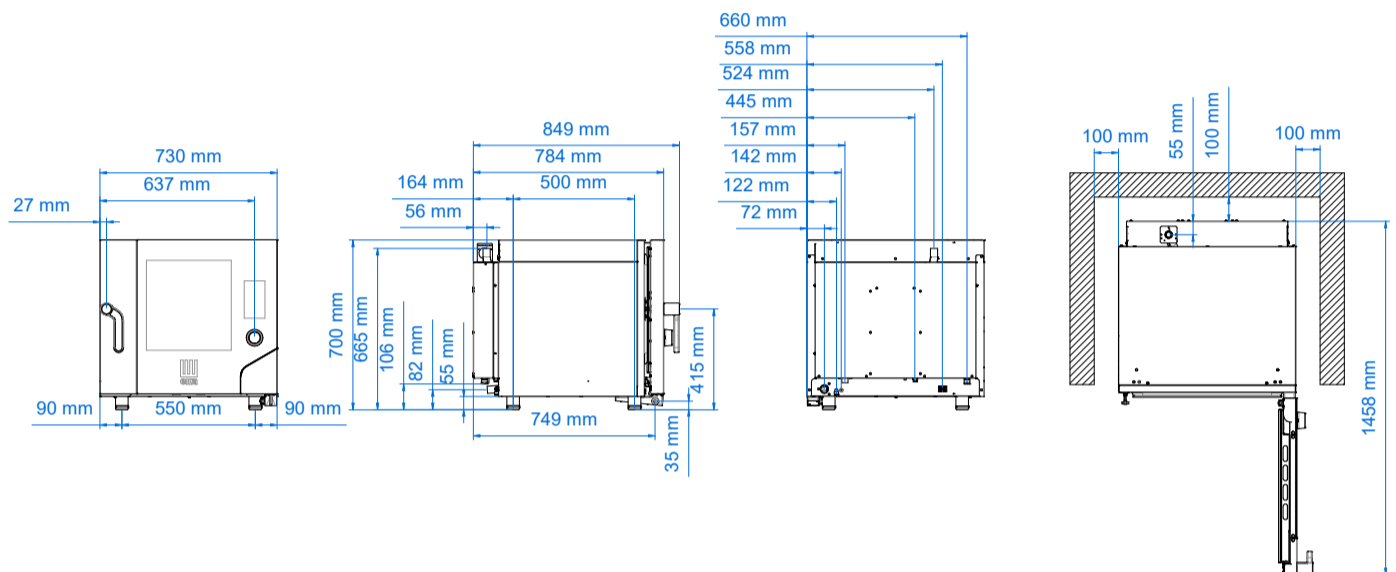

Electric combi oven 5 trays 1/1 GN  
with TOUCH SCREEN



## Dimensional features

Dimensions (WxDxH mm)	730 x 849 x 700
Weight (kg)	78,4
Distance between rack rails (mm)	68

## Electrical features

Power supply (kW)	7,8
Frequency (Hz)	50/60
Voltage (V)	AC 380/400 3N
N° motors	1 bidirectional
Boiler (kW)	/
Protection against water	IPX5

## Functional features

Power	Electricity
Capacity	5 trays/grids 1/1 GN
Type of cooking	Semistatic + ventilated
Steam	Direct steam controlled by touch screen (10 levels)
Cooking chamber	AISI 304 stainless steel
Temperature	30 - 270 °C
Temperature control	Digital probe thermometer
Control panel	Touch screen
N° programs	500
Programmable cooking steps	10
Pre-heating temperature	180 °C
Pre-heating function	Programmable
Door	Right side opening Ventilated Inspectionable glass
Modularity	Yes
Feet	Adjustable

## Optionals

Condensation hood	<b>MKCC 5</b>
Kit for overlapping ovens	<b>MKS 11</b> <b>MKSST 511</b>
Tables	<b>MKTS 11</b> <b>MKT 11 D</b>
Holding cabinet	<b>MKM 1211</b>
Other accessories	Available in the dedicated section

## Equipment

Cardboard box dimensions with pallet (WxDxH mm)	790 x 905 x 865 mm
Lateral supports	1 right + 1 left
Cable	Three-phase+neutral [5G 1,5]-L=1600 mm
USB port	
Multipoint core probe cod. MKSCMU/A	
Support for core probe cod. MKSSC/A	
Automatic washing system integrated	
Condensate collection bowl, with drain on door	
Hinge with door locking for openings adjusted at 60°, 90°, 120°, 180°	

## Plus

Patented fan guard system <b>Airflowlogic™</b>	
Patented system for direct steam <b>Humilogic™</b>	
Patented system for cooking chamber drying <b>Drylogic™</b>	
Available on request at the order	Voltage (V) : AC 220/230 3 PH Voltage (V) : AC 220/230 Left side opening door
Humidity management software	
Wi-Fi communication system	
Knob for quick selection of the touch screen	
Programmable oven start	
N° 40 recipes stored	
Control panel in 42 languages:	Arabic, Armenian, Azerbaijani, Bahasa (Indonesia), Bahasa (Malaysia), Bosnian, Bulgarian, Chinese, Croatian, Czech, Danish, Dutch, English, Estonian, Finnish, French, Georgian, German, Greek, Hungarian, Icelandic, Italian, Japanese, Kazakh, Latvian, Lithuanian, Norwegian, Persian (Iran), Philippine, Polish, Portuguese, Romanian, Russian, Serbian, Slovenian, South Korean, Spanish, Swedish, Thai, Turkish, Ukrainian, Vietnamese
HACCP system	
Adjustable door hinges	