

Professional graters for heavy duty production.  
Ideal for grating Parmesan and other hard cheeses,  
bread and almonds. Reliable and user friendly.  
Suitable for use in large commercial kitchens.



Heavy Duty; Direct Drive; Manual Operation

Model  
**CEGF3/5**  
Cheese Graters

# Model CEGF3/5 Cheese Graters

The CEGF3 and CEGF5 Graters have been designed for grating hard cheeses of all kinds, and copes particularly well with nuts and breads.

With their large capacity inlet and outlet, powerful motor and comprehensive safety features, the versatile CEGF3 and CEGF5 Graters can handle hard work with ease.

- All components coming into contact with food are made from stainless steel.
- Large inlets and grid-free outlet for clog-free operation.
- Stainless steel inlet is removable for easy cleaning (CEGF5 only).
- Containers fitted with safety cut-out sensor and shield.
- Low voltage (240V) N.V.R. switching for added operator safety.
- CE Approved.

## SPECIFICATIONS

	CEGF3	CEGF5
Motor	3Hp (2200w)	5.5Hp(4100w)
Motor RPM	1,400	1,400
<b>Dimensions (mm)</b>		
WxDxH	725x555x590	915x740x920
Production capacity		
kg/hr	200	500
Net weight (kg)	42	110

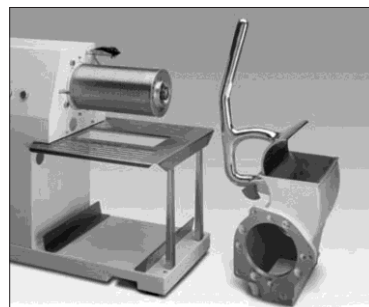
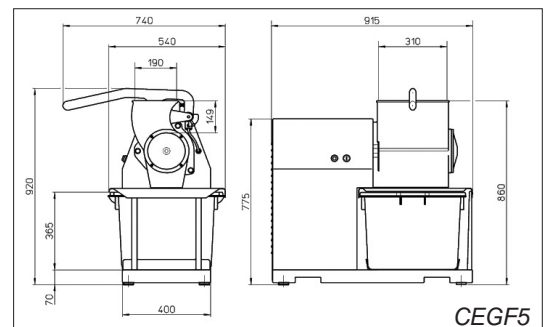
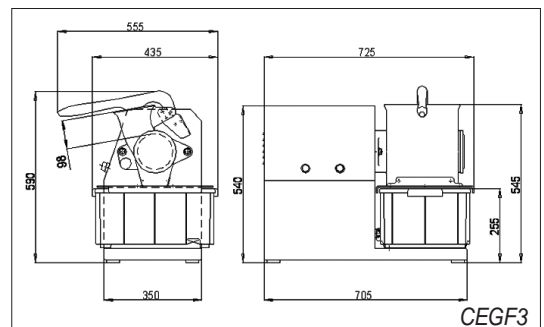

The CEGF5 disassembles for easy cleaning.

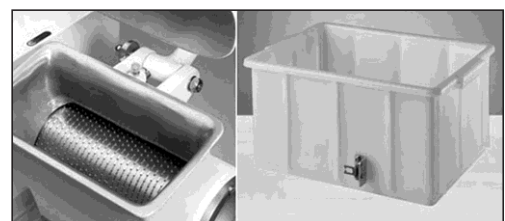

Large inlet

Large receiving tub



Servicing NSW and ACT

Ph: 02 4879 3808

[www.briquip.com.au](http://www.briquip.com.au)

[admin@briquip.com.au](mailto:admin@briquip.com.au)