

The GPR series of manual slicers are light duty and belt driven. Available in a range of sizes, they are ideal for caterers, restaurants, small/medium kitchens and delicatessens.



Light Duty; Belt-Driven; Manual Operation

Model
GPR

Belt Driven Slicers

Model

Belt Driven Slicers

The Model GPR series of belt-driven food slicers have been designed for precision slicing. Perfect for small cafés, restaurants and convenience stores.

Features:

- Manufactured in anodised aluminum and stainless steel to resist the corrosive effects of salts and acids.
- Removable carriage for easy cleaning.
- Micrometric adjusting knob allows for cutting of slices up to 15mm.
- Self-contained inbuilt and shielded sharpening device.
- Forced ventilation to motor.
- Belt driven blade.
- Blade ring guard.
- Low voltage switching.
- Safety guard.
- Extended LSD handle.
- Mechanical safety interlock to prevent the blade being exposed when the carriage is removed for cleaning. (Model 300 only).

SPECIFICATIONS

	220	250	300
Dimensions (mm)			
Width	360	420	450
Depth	460	540	600
Height	350	350	400
Blade (mm)	220	250	300
Power	150W	180W	220W
240V single phase motor	50Hz		
Operating Temp Range	+5°C - +40°C		
Net weight (kg)	12.5	15	23
Max. Slice thickness (mm)	15		
IP Rating	21		

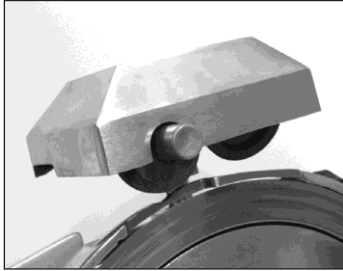

The built-in sharpener is simple and safe to operate.

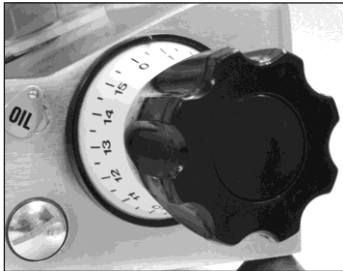

Precision adjustment of slice thickness.

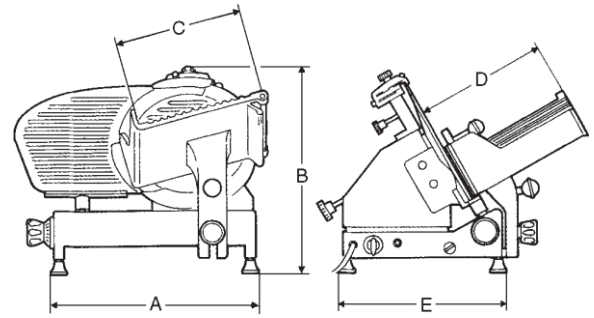

GPR220



GPR250



GPR300

CE Approved



Servicing NSW and ACT

Ph: 02 4879 3808

www.briquip.com.au

admin@briquip.com.au