

The MAN370VKBV manual slicer is a heavy-duty slicer with a large slicing capacity, perfect for bacon and fresh meats. The powerful motor and gear-driven blade mean the MAN370VKBV can operate in even the busiest high-volume delicatessen or butchers.

- **Gear Drive**
Powerful, heavy duty operation with fan-cooled motor for continuous service
- **Comprehensive electrical and mechanical safety features**
- **Large slicing capacity**
Ideal for larger portions of meat.
- **Built in sharpener**
Easy operation means great cuts every time.
- **Easy cleaning**
Machine disassembles quickly for effective cleaning
- **CE approved.**



Model
MAN370VKBV

Vertical Slicer

Model MAN370VKBV Vertical Slicer

CE Approved

The MAN370VKBV Vertical slicer has been designed especially for slicing fresh meat.

With its large capacity meat table, the versatile 370VKBV can handle any meat product – from small salami and sausages, up to full size sides of bacon.

- Manufactured in stainless steel and anodised aluminum to resist the corrosive effects of salts and acids.
- Constructed for easy and friendly cleaning.
- Micrometric adjusting knob allows for cutting of slices up to 24mm.
- Built-in dual action sharpener ensures a long-lasting razor-sharp knife.
- Forced ventilation to motor.
- Gear driven blade.
- CE Approved.

SPECIFICATIONS

| | |
|------------------------------|----------------------------------|
| Blade (mm) | 370 |
| Motor | 240V single phase, 50Hz, 290W |
| Dimensions WxDxH (mm) | 686 x 845 x 569 |
| Slice Capacity | |
| Rectangular (mm) | 320 x 260 |
| Circular/Diameter (mm) | 260 |
| Max. Slice thickness (mm) | 24 |
| Net weight (kg) | 55 |
| IP Rating | IPx3 (Motor IPx5) |



The built-in sharpener is simple and safe to operate.



Precision slicing with the micrometric slice thickness knob.



The generously sized meat tray can handle whole sides of bacon, and the smooth double-action movement reduces slicing effort.

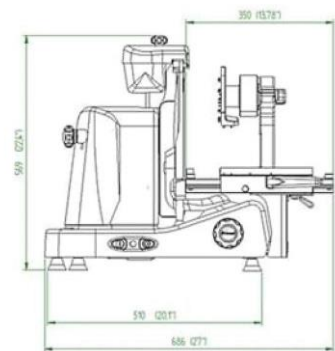
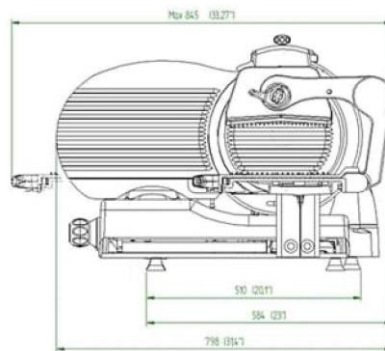

Servicing NSW and ACT

Ph: 02 4879 3808

www.briquip.com.au

admin@briquip.com.au