

Mechanical pallet passages open to exactly the width that hand-lift trucks and forklifts with Euro pallets require to pass through. Transport trolleys, large containers and staff members can also pass through.

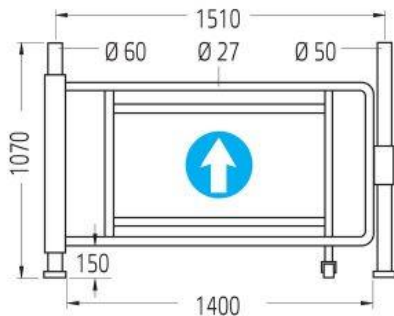

Design

Sturdy steel tube design with support castor. Finish: high-gloss chrome-plated. Plastic sign, printed on both sides.



“Double-sided” function

The door is held closed using a lock with a sprung fixing roller and can be opened in both directions by applying counter-pressure.

“Right and left opening” function

The door is unlocked with a standard cylinder lock (integration in locking system possible) and can then be opened in the appropriate direction.

