

The Chef Food Slicer & Grater is perfect for moderate to high-volume use in larger restaurants, supermarkets and delicatessens.



Model
CHEF300
Food Slicer & Grater

Model CHEF300

Food Slicer & Grater

CE Approved

The Chef Food Slicer & Grater has been designed for moderate to high-volume use in larger restaurants, supermarkets and delicatessens.

Convenience features include, fast blade change and dual inlet chutes, which make for fast and efficient slicing of any kind of fruit or vegetable in the busiest environment.

- Manufactured in anodised aluminum and stainless steel to resist the corrosive effects of salts and acids.
- Constructed for easy cleaning.
- Up to 60 different slicing and grating combinations.
- Safety interlock switches prevent operation if the machine is opened, or the feeder handle is not closed.
- Forced ventilation to motor.

SLICING DISCS

E1, E2, E3, E4, E6, E8, E10 & E14: For slices from 1 to 14 mm. Potato chips, potato, turnip, cabbage, cucumber, carrot, mushroom, onion, marrow, aubergine, fennel, artichoke.

E5, E1S & E2S: For slices from 1 to 5 mm. Hard salami, mushroom, tomato, lemon, orange, apple, banana, pineapple, grapefruit, etc.

E3o, E4o, E6o, E8o, E10o, & E14o: For fruit and vegetable waved slices from 1 to 14 mm.

VE3, VE4, VE, 6 & VE 8: Use to slice complete vegetables. White cabbage, red cabbage, etc.

SPECIFICATIONS

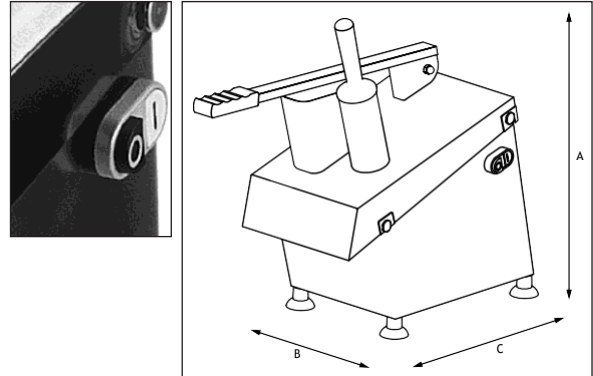

MATCH-LIKE CUTTING DISCS

H2.5, H4, H6, H8 & H10: Celery, marrow, beetroot, carrot, potato, cabbage, etc.

SHREDDING OR GRATING DISCS

Z2, Z3, Z4 & Z7: Carrot, celery, potato, apple, turnip, beetroot, red cabbage, cheese, chocolate, etc.

V: Cheese, dry bread, nuts, chocolate, etc.

CUBIC CUTTING DISCS

D8x8, D10x10, D12x12, D16x16 & D20x20: Used in combination with any of the E series discs produces three different sizes of cubes or strips for use in soups, fruit salads, etc.

CHIPPING GRID DISCS

B6, B8 & B10: Use in combination with E series discs to obtain matchlike chips. Use with the Eo series discs to produce chips with waved sides.

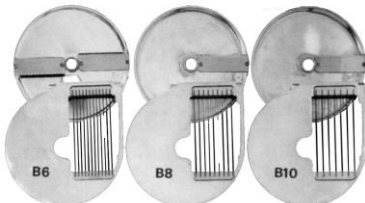
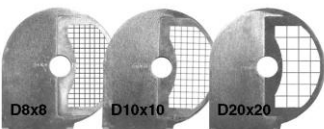
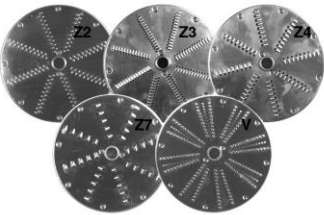
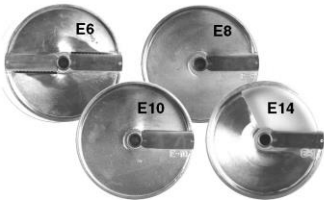

Servicing NSW and ACT

Ph: 02 4879 3808

www.briquip.com.au

admin@briquip.com.au