

The “Black Edition” gravity-feed manual slicer is a heavy duty machine designed for slicing a range of meat products. An ideal slicer for restaurants, caterers, medium/large kitchens and delicatessens.

- **Belt Driven**
Powerful and hard-working.
- **Comprehensive electrical and mechanical safety features**
- **Built in sharpener**
Easy operation means great cuts every time
- **Easy cleaning**
Machine disassembles quickly for effective cleaning.
- **CE approved.**



Model
BLACK EDITION
Gravity-feed Slicer

Model BEG

“BLACK EDITION” Gravity-feed Slicer

CE Approved

The heavy-duty Model BEG “Black Edition” Gravity-feed slicer has been designed to handle meats of all kinds.

- Built-in blade sharpener
- Adjustable slice thickness up to 14mm
- Forced ventilation to motor.
- NVR*
- Blade ring guard
- Blade diameter: 300mm, 350mm, 370mm
- Mechanical safety interlock to prevent the blade being exposed when the carriage is removed for cleaning.
- Large meat tray.
- CE approved.

SPECIFICATIONS

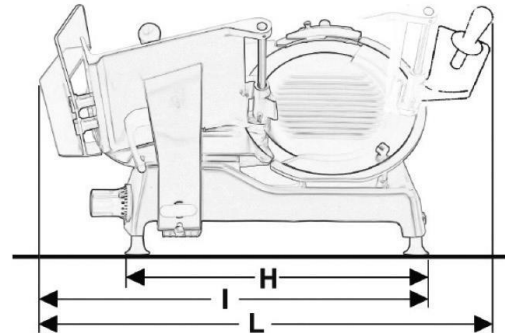
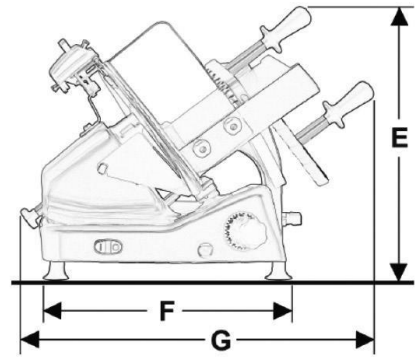

	BEG30	BEG35	BEG37
Blade (mm)	300	350	370
Motor	240V single phase, 50Hz, 250W	240V single phase, 50Hz, 270W	240V single phase, 50Hz, 270W
Overall Dimensions WxDxH (mm)	(GxLxE) 670x750x515	(GxLxE) 760x800x560	(GxLxE) 760x890x630
Footprint WxD (mm)	(FxH) 410x510	(FxH) 480x600	(FxH) 480x600
Slice Capacity			
Rectangular (mm)	240x220	275x285	290x290
Circular/ Diameter (mm)	200	255	265
Max. Slice Thickness (mm)	14	14	14
Net weight (kg)	34	38	41
iP Rating	55	55	55

*NVR – No Voltage Release. This safety feature will engage if there is an interruption to the power supply. The machine will not automatically restart once the power is restored. The machine can be re-set by pushing the ON/OFF button.