

A workhorse vertical slicer that is ideal for slicing fresh and processed meats, thanks to the liftable double plate product tray. A heavy-duty belt-driven motor makes slicing a breeze.

- **Belt drive**  
Powerful, heavy duty operation with fan-cooled motor for continuous service
- **Comprehensive electrical and mechanical safety features**
- **Large slicing capacity**  
Ideal for larger portions of meat.
- **Built in sharpener**  
Easy operation means great cuts every time.
- **Easy cleaning**  
Machine disassembles quickly for effective cleaning.
- **CE approved.**



Model

**BEM35/37**

“Black Edition” Vertical Slicer



Heavy Duty; Belt-driven; Manual Operation

# Model BEM35/37 Vertical Slicer

The Model BEM35/37 "Black Edition" Flatbed slicer has been designed especially for slicing fresh meats of all kinds, and copes particularly well with larger portions.

With its large capacity meat table, the versatile BEM can handle any meat product – from small salami and sausages, up to full size sides of bacon.

- Manufactured in stainless steel and anodised aluminum to resist the corrosive effects of salts and acids.
- Constructed for easy and friendly cleaning.
- Micrometric adjusting knob allows for cutting of slices up to 22mm.
- integrated and removable sharpening device.
- Forced ventilation to motor.
- Belt driven blade.
- Safety cutout switches for blade operation and blade cover.

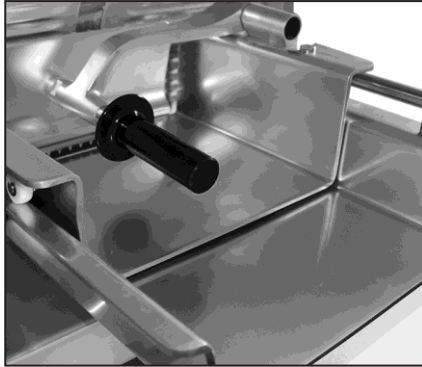

Large double-carriage meat tray



The integrated and removable sharpening device is simple and safe to operate.



Moisture-proof, low-voltage micro-switches control the machine.

## SPECIFICATIONS

	BEM35	BEM37
Blade (mm)	350	370
240V single phase motor	250W, 50Hz	270W, 50Hz

### Dimensions

Width (G) (mm)	710	710
Depth (L) (mm)	910	910
Height (M) (mm)	680	680

### Slice Capacity

Rectangular (mm)	320 x 260 (h)	320 x 280 (h)
Circular (mm)	260 (diameter)	280 (diameter)
Max. Slice thickness (mm)	25	25
Net weight (kg)	41	42

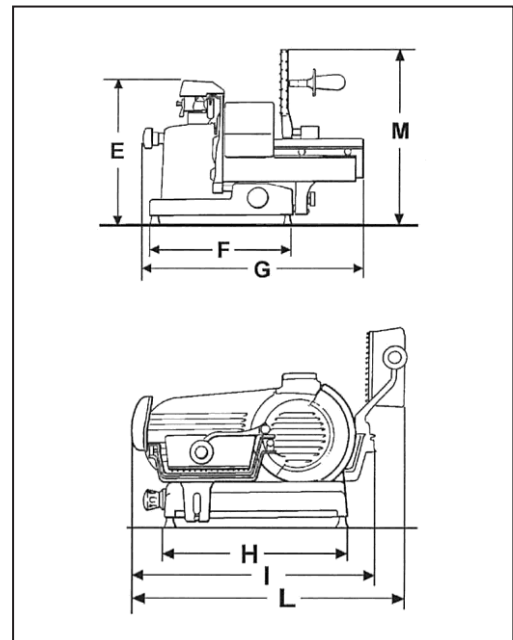

Servicing NSW and ACT

Ph: 02 4879 3808

[www.briquip.com.au](http://www.briquip.com.au)

[admin@briquip.com.au](mailto:admin@briquip.com.au)