

MKL 1064 S

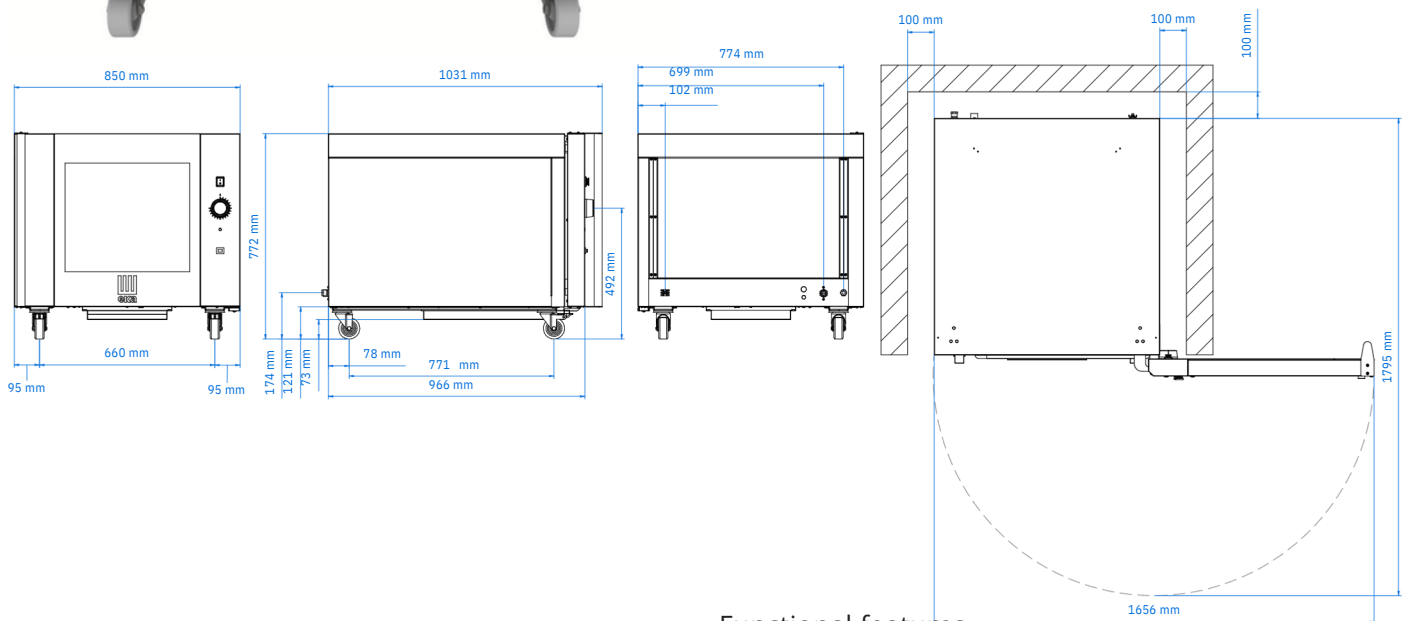

Electric proofer for 4, 6 and 10 trays ovens S

Sometimes nothing is more indispensable than an accessory. That's why we designed the MKL 1064 S, elegant in design and perfected in performance. The ideal solution for significantly reducing rising times without compromising the sensory properties of your preparations, because the MILLENNIAL line always means top quality.



Functional features

Dimensional features

Dimensions (WxDxH mm)	850 x 1030 x 770
Weight (kg)	91
Distance between rack rails (mm)	85

Electrical features

Power supply (kW)	2,4
Frequency (Hz)	50/60
Voltage (V)	AC 220/230
Protection against water	IPX4

Power	Electricity
Capacity	N° 10 trays/grids 600 x 400
Steam	mm Indirect with button
Proofing chamber	AISI 430 stainless steel
Temperature	25 - 65 °C
Temperature control	Thermostat
Control panel	Electromechanic - right side
Pre-heating	/
temperature Door	Right side opening

Equipment

Cardboard box dimensions with pallet (WxDxH mm)	870 x 1120 x 900
Lateral supports	1dx + 1sx
Cable	Single-phase [3G 1,5]-L=1600 mm
Removable drip box	
Set of wheels	MKKR



Servicing NSW and ACT

Ph: 02 4879 3808
www.briquip.com.au
admin@briquip.com.au