

EKF 423 NT UD

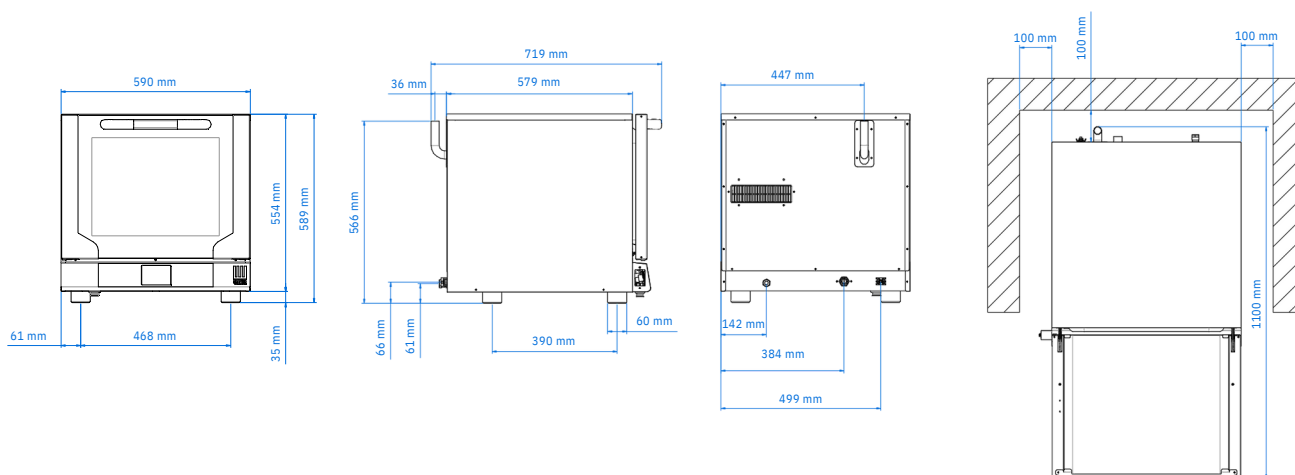

ELECTRIC COMBI OVEN WITH TOUCH SCREEN AND DIRECT STEAM



DIMENSIONAL FEATURES			
Oven dimensions (WxDxH mm)	590	719	589
Oven weight (kg)	38		
Distance between rack rails (mm)	74		

ELECTRICAL FEATURES	
Power supply (kW)	3,15
Frequency (Hz)	50/60
Voltage (Volt)	AC 220/230
N° of motors	1 Bidirectional
B oiler	/
Protection against water	IPX4

EQUIPMENT			
Cardboard box dimensions (WxDxH mm)	650	760	600
Aluminium tray 429x345	4 pcs (cod. KV7)		
Lateral supports	1 right + 1 left		
Cable	Single-phase [3G 1,5]-L=1600 mm		
USB port			

FUNCTIONAL FEATURES	
Power	Electricity
Capacity	N° 4 trays/grids 429x345 mm
Type of cooking	Ventilated
Steam	Direct steam controlled by touch screen and 10-step display [%]
Cooking chamber	AISI 304 Stainless steel
Temperature	30 - 260 °C
Temperature control	Digital probe thermometer
Control panel	Touch-Lower side
N° of programs	100
Programmable cooking steps	5
Pre-heating temperature	180 °C
Pre-heating function	Available
Programmable oven start	Available
Door	Tilt door Ventilated Inspectionable glass
Modularity	Available

PLUS	
Core probe setup (on request)	
Core probe (on request)	
Core probe support (on request)	
Wi-Fi module (on request)	



Servicing NSW and ACT

Ph: 02 4879 3808
www.briquip.com.au
admin@briquip.com.au