

MKF 1064 TS

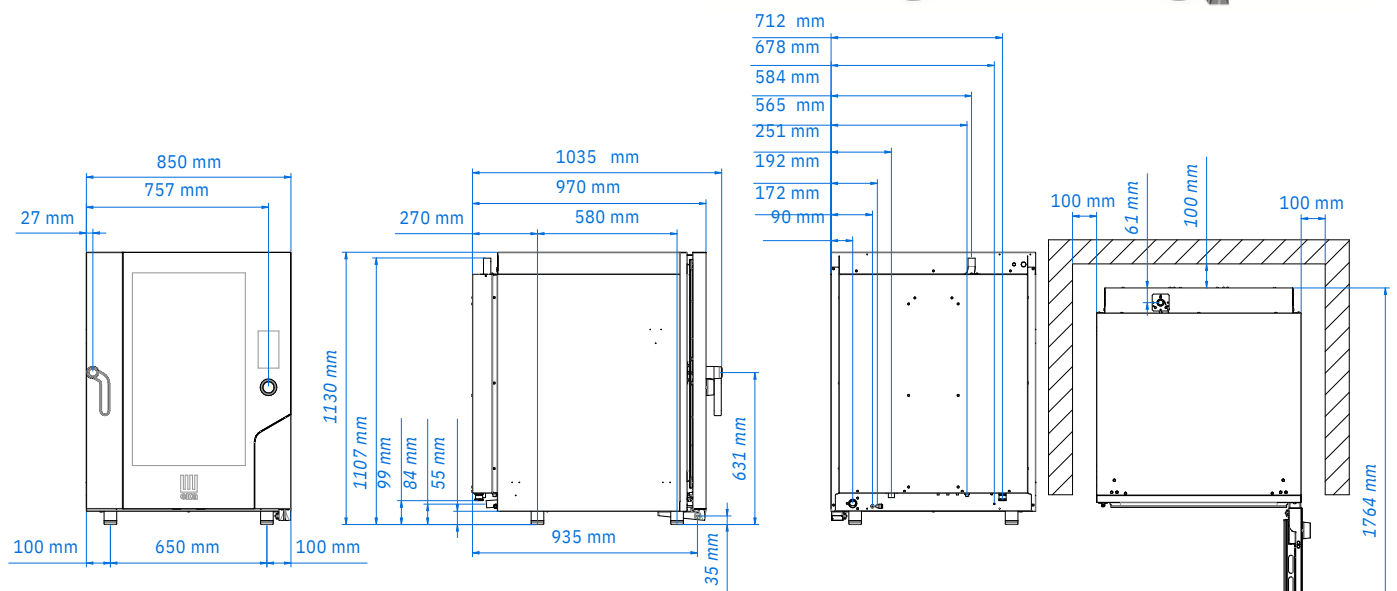

Electric combi oven 10 trays
600 x 400 mm with TOUCH SCREEN



Dimensional features

Dimensions (WxDxH mm)	850 x 1035 x 1130
Weight (kg)	140,4
Distance between rack rails (mm)	80

Electrical features

Power supply (kW)	17
Frequency (Hz)	50/60
Voltage (V)	AC 380/400 3N
N° motors	3 bidirectionals
Boiler (kW)	7
Protection against water	IPX5

Functional features

Power	Electricity
Capacity	10 trays/grids 600 x 400 mm
Type of cooking	Semistatic + ventilated
Steam	Direct steam controlled by touch screen (10 levels)
Cooking chamber	AISI 304 stainless steel
Temperature	30 - 270 °C
Temperature control	Digital probe thermometer
Control panel	Touch screen
N° programs	500
Programmable cooking steps	10
Pre-heating temperature	180 °C
Pre-heating function	Programmable
Door	Right side opening Ventilated Inspectionable glass
Modularity	Yes
Feet	Adjustable

Optionals

Condensation hood	MKCC 610
Kit for overlapping ovens	MKS 64
Tables	MKTS 64 MKT 64 D
Proofer and holding cabinet	MKLM 1064
Other accessories	Available in the dedicated section

Equipment

Cardboard box dimensions with pallet (WxDxH mm)	910 x 1090 x 1295 mm
Lateral supports	1 right + 1 left
Cable	Three-phase+neutral [5G 4]-L=1600 mm
USB port	
Multipoint core probe cod. MKSCMU/A	
Support for core probe cod. MKSSC/A	
Automatic washing system integrated	
Condensate collection bowl, with drain on door	
Hinge with door locking for openings adjusted at 60°, 90°, 120°, 180°	

Plus

Patented fan guard system Airflowlogic™	
Patented system for direct steam Humilogic™	
Patented system for cooking chamber drying Drylogic™	
Available on request at the order	Voltage (V) : AC 220/230 3 PH Left side opening door
Humidity management software	
Wi-Fi communication system	
Knob for quick selection of the touch screen	
Programmable oven start	
N° 40 recipes stored	
Control panel in 42 languages:	Arabic, Armenian, Azerbaijani, Bahasa (Indonesia), Bahasa (Malaysia), Bosnian, Bulgarian, Chinese, Croatian, Czech, Danish, Dutch, English, Estonian, Finnish, French, Georgian, German, Greek, Hungarian, Icelandic, Italian, Japanese, Kazakh, Latvian, Lithuanian, Norwegian, Persian (Iran), Philippine, Polish, Portuguese, Romanian, Russian, Serbian, Slovenian, South Korean, Spanish, Swedish, Thai, Turkish, Ukrainian, Vietnamese
HACCP system	
Adjustable door hinges	



Servicing NSW and ACT

Ph: 02 4879 3808

www.briquip.com.au

admin@briquip.com.au