

# MKF 1664 TS

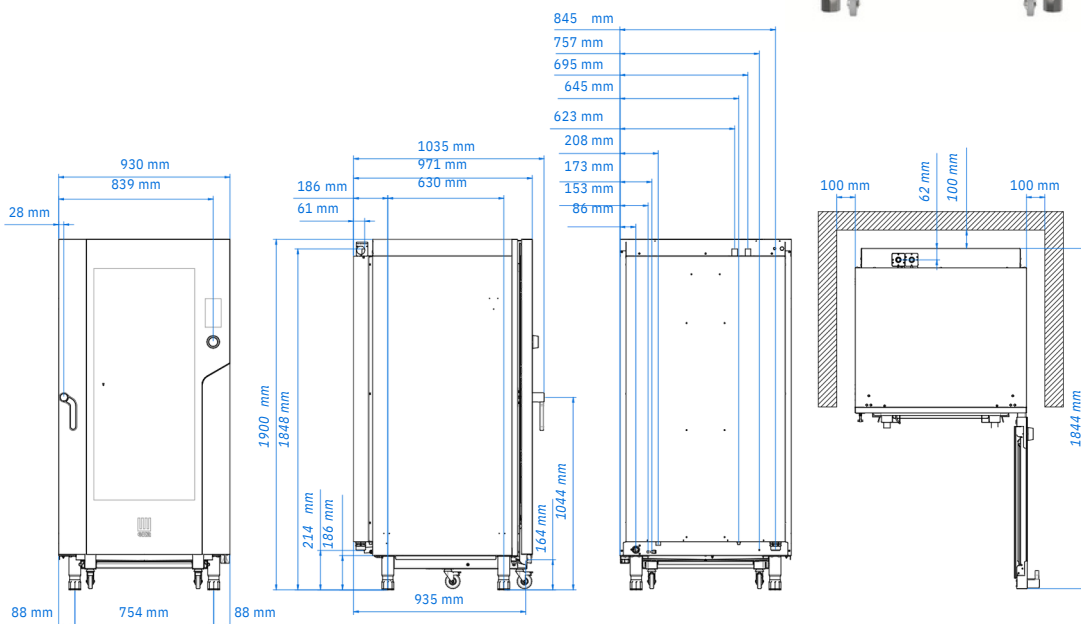

Electric combi oven 16 trays  
600 x 400 mm with TOUCH SCREEN



## Dimensional features

Dimensions (WxDxH mm)	930 x 1035 x 1900
Weight (kg)	247,2
Distance between rack rails (mm)	80

## Electrical features

Power supply (kW)	31
Frequency (Hz)	50/60
Voltage (V)	AC 380/400 3N
N° motors	4 bidirectionals
Boiler (kW)	7
Protection against water	IPX5

## Functional features

Power	Electricity
Capacity	16 trays/grids 600 x 400 mm
Type of cooking	Semistatic + ventilated
Steam	Direct steam controlled by touch screen (10 levels)
Cooking chamber	AISI 304 stainless steel
Temperature	30 - 270 °C
Temperature control	2 Digital probe thermometers
Control panel	Touch screen
N° programs	500
Programmable cooking steps	10
Pre-heating temperature	180 °C
Pre-heating function	Programmable
Door	Right side opening Ventilated Inspectionable glass
Feet	Adjustable

## Optionals

Condensation hood	MKCC 1620
Trolleys	EKCR 16 TC EKCR 1664
Other accessories	Available in the dedicated section

## Equipment

Cardboard box dimensions with pallet (WxDxH mm)	1146 x 1260 x 2090 mm
USB port	
Multipoint core probe cod. MKSCMU/A	
Support for core probe cod. MKSSC/A	
Automatic washing system integrated	
Hinge with door locking for openings adjusted at 60°, 90°, 120°, 180°	
Trolley with removable handle and braked wheels cod. EKCR 16 TC	

## Plus

Patented fan guard system Airflowlogic™	
Patented system for direct steam Humilogic™	
Patented system for cooking chamber drying Drylogic™	
Voltage (V) : AC 220/230 3 PH	
Available on request at the order	Left side opening door
Humidity management software	
Wi-Fi communication system	
Knob for quick selection of the touch screen	
Programmable oven start	
N ° 40 recipes stored	
Control panel in 42 languages:	
Arabic, Armenian, Azerbaijani, Bahasa (Indonesia), Bahasa (Malaysia), Bosnian, Bulgarian, Chinese, Croatian, Czech, Danish, Dutch, English, Estonian, Finnish, French, Georgian, German, Greek, Hungarian, Icelandic, Italian, Japanese, Kazakh, Latvian, Lithuanian, Norwegian, Persian (Iran), Philippine, Polish, Portuguese, Romanian, Russian, Serbian, Slovenian, South Korean, Spanish, Swedish, Thai, Turkish, Ukrainian, Vietnamese	
HACCP system	
Adjustable door hinges	



Servicing NSW and ACT

Ph: 02 4879 3808

[www.briquip.com.au](http://www.briquip.com.au)

[admin@briquip.com.au](mailto:admin@briquip.com.au)